

DETAIL A

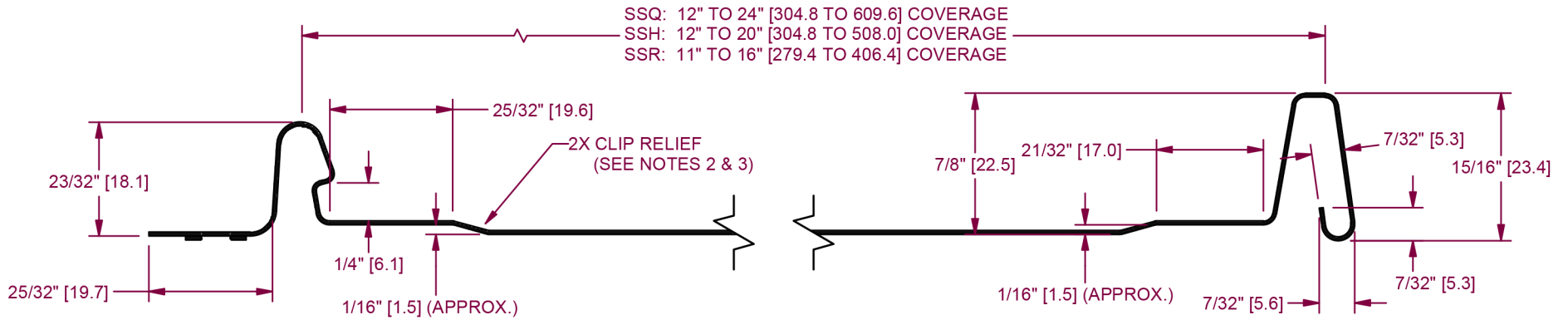
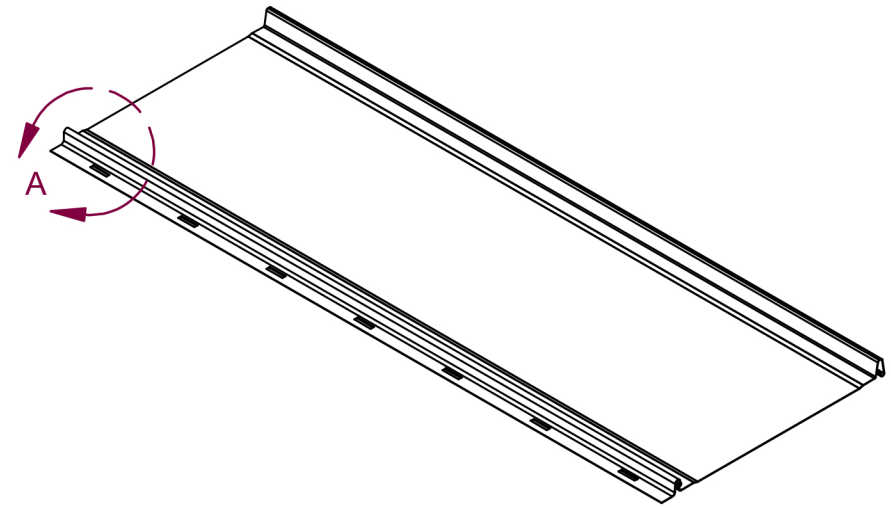

3 ADDED SSH AND SSR PANEL WIDTHS

- NOTES:
1. MATERIAL USAGE: 4 1/16" APPROX.
 2. CLIP RELIEF ROLLERS ARE STANDARD WITH THIS PANEL.
 3. PANEL IS SHOWN WITH CLIP RELIEF ROLLERS ENGAGED.
 4. DUAL DIMENSIONS: Inch [mm]

MATERIAL PAINTED STEEL/PAINTED ALUMINUM/COPPER			FINISH NONE		
REVISION HISTORY	REV	ECR NO.	DATE	RELEASED BY	TOLERANCES
	1	REDRAWN	01/17/08	JD	.XX = ± .01
	2	R-1796	09/22/2011	AJB	.XXX = ± .005
	3	R-2368	6/11/2020	AJB	FRACTION = ± 1/32"
					ANGLE = ± 1/2°

		PART NAME		
		FF100 PANEL PROFILE		
DRAWN BY DeBerard DATE 06/25/2002	CHECK BY FRY DATE 01/17/2008	PART NUMBER	SHEET	REVISION
		FF1-FF1	1 OF 1	3